



SCL

Reguladora de fluxo com fenda

Série SCL

Reguladora de fluxo com fenda

AKME
SOLUÇÕES EM AUTOMAÇÃO



Codificação

SCL

Modelo

-

Rosca

01 - 1/8"

02 - 1/4"

03 - 3/8"

04 - 1/2"

Simbologia

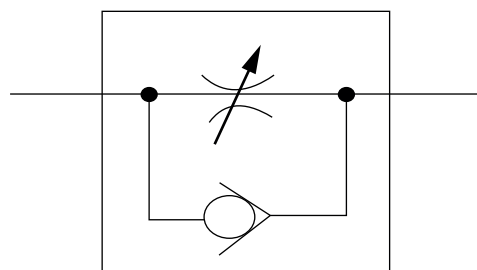

Especificação

Modelo	SCL-01	SCL-02	SCL-03	SCL-04
Fluído	Ar			
Pressão de Trab. (Bar)	10			
Temp. de trabalho (°C)	-5 á 80°C			
Vazão (l/min)	250	450	850	1600

Série SCL

Reguladora de fluxo com fenda

Dimensão Geral

SCL 01 ~ SCL 04

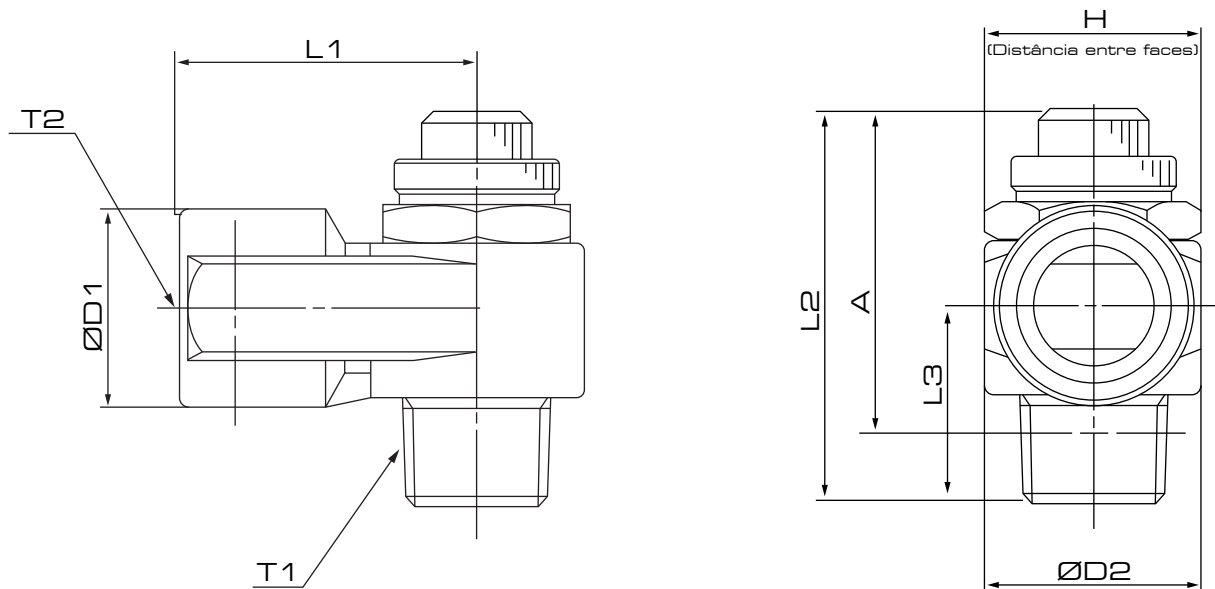

Dimensões

Modelo	T1	T2	H	L1	L2		L3	D1	D2	A	
					Máx.	Mín.				Máx.	Mín.
SCL-01	1/8"	1/8"	12	23	44	39	15	13	14	35	30
SCL-02	1/4"	1/4"	15	25	45	38	18	18	19.5	36.3	29.2
SCL-03	3/8"	3/8"	19	30	46.9	41.9	20.8	22.5	24.3	40.6	35.6
SCL-04	1/2"	1/2"	24	38.5	55.6	50.6	26.7	27.5	28.5	47.4	42.4