



KA

Check Valve

KA Series

Check Valve

AKME
SOLUÇÕES EM AUTOMAÇÃO



SOLUÇÕES EM AUTOMAÇÃO

Ordering Code

KA

06

Series Code

KA: Check Valve

Port Size

01: G1/8"

02: G1/4"

03: G3/8"

04: G1/2"

06: G3/4"

Symbol

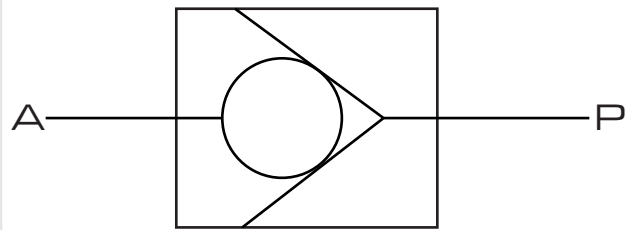

Specification

Model	KA-01	KA-02	KA-03	KA-04	KA-06
Working pressure	0.5 ~ 8 Bar				
Environment temperature	-10~+55°C				
Medium temperature	0~+55°C				
Circulating Ability	10	20	40	60	110
Startup Ability	≤0.3 Bar				
Leak Out Flow (cm ³ /min)	50	50	120	120	250
Respond time (Sec)	0.03				
Life Ten Thousand times	≥150				

KA Series

Check Valve

Overall Dimension

KA Series

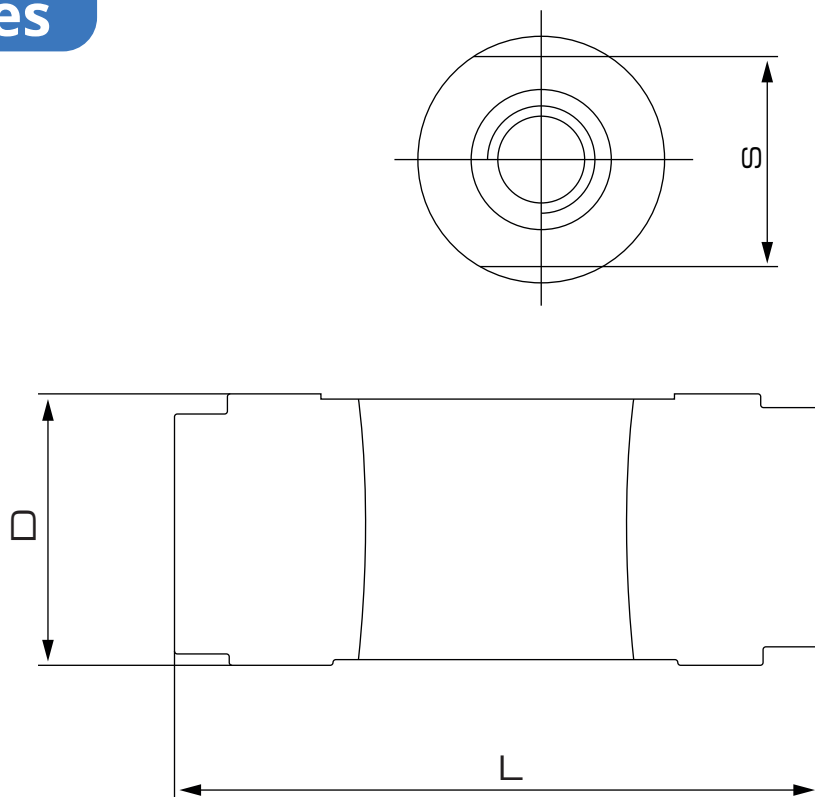

Dimension

Model	Joint Pipe Code	D2	S	L
KA-01	01	Ø28	24	64
KA-02	02	Ø28	24	64
KA-03	03	Ø40	36	86
KA-04	04	Ø40	36	86
KA-06	06	Ø55	46	112