

BE, BE12

ISO 5599/1

BE/BE12 Series

ISO 5599/1 Valves

AKME
SOLUÇÕES EM AUTOMAÇÃO

BE/BE12

ISO 5599/1 Valves

- Complying with ISO 5599/1 international standards
- Full range: 1 - 2 - 3 - 4 size
- Two different internal commutation systems mixed and spool
- High capacity
- Short internal stroke
- No lubrication
- Electric connection M12 for Automotive sector (1 -2 -3 sizes)
- Modular and single bases
- Possibility of combination of different sub-base sizes with proper interfaces

BE/BE12 Series

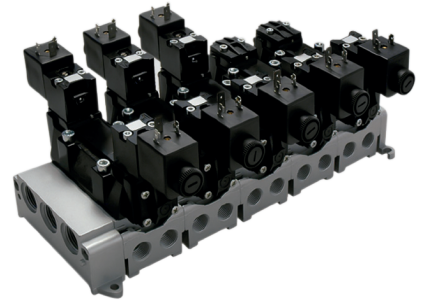

TECHNICAL CHARACTERISTICS

Ambient temperature	-10 ÷ +50 °C			
Fluid temperature	Max +50 °C			
Fluid	50 µm filtered air (mixed system) 50 µm filtered air, with or without lubrication (spool system)			
Commutation system	mixed system, spool system			
Ways/Positions	5/2, 5/3			
Pressure	10 bar Max			
Control	indirect electro-pneumatic, pneumatic			
Return	mechanical spring, pneumomechanical spring, pneumatic, electric			
Connections	ISO 5599/1 interface			
	size 1	size 2	size 3	size 4
Nominal Ø (mm)	8	10	15	19
Nominal flow rate (NI/min)	1480	2300	4200	6600

CONSTRUCTIVE CHARACTERISTICS

Valve body	acetalic resin
Cover	aluminium
Seals	mixed system: nitrile rubber and polyurethane spool system: nitrile rubber
Sub-base	zamak - aluminium
Actuators	technopolymer
Spool	aluminium

ELECTRIC CHARACTERISTICS

Electropilot	AA series
Coil	U3
Power consumption	2,5 W (DC) - 5 VA (AC)
Voltage	12 V DC - 24 V DC - 24 V AC - 110 V AC - 230 V AC
Connector	AM 5111
Manual override	impulse screw - 2 positions, button with tool (BE) recessed button - 1 position (BE12)



MIXED
for heavy applications



SPOOL
for all applications

Flow rate characteristics

>> ISO 1

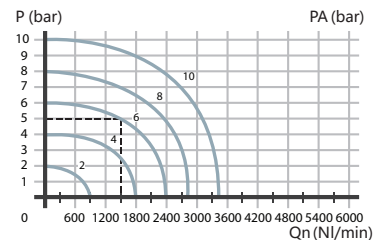

>> ISO 2

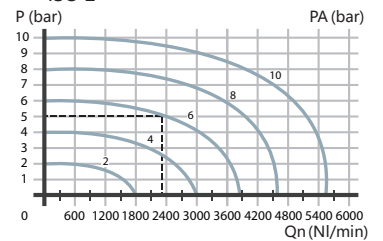

>> ISO 3

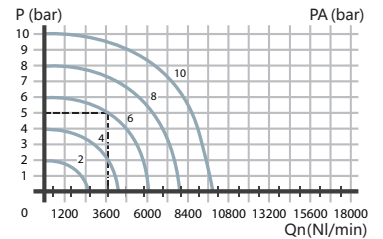

>> ISO 4

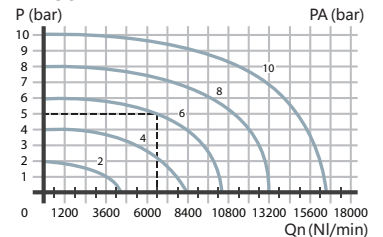

P = Working pressure
PA = Supply pressure
Qn = Nominal flow rate

BE/BE12 Series

ISO 5599/1 Valves

BE/BE12 Normativa ISO 5599/1

ISO 5599/1 Standard

The ISO standard for pneumatic valves is accepted by industry and by the majority of the main important pneumatic valve manufactures throughout the world. The choice of valves according to ISO standard guarantees to the user the interchangeability of both the valve body and the electromagnetic part.

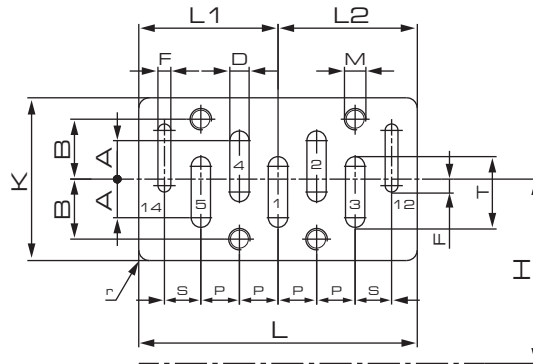

	A	B	D	F	H	K	L	L1	L2	M	P	r	S	T
ISO 1	9	14	4,5	3	43	38	65	32,5	32,5	M5	9	2,5	8,5	16,5
ISO 2	10	19	7	3	56	50	81	40,5	40,5	M6	12	3	10	22
ISO 3	11,5	24	10	4	71	64	106	53	53	M8	16	4	13	29
ISO 4	14,5	29	13	4	82	74	142	77,5	64,5	M8	20	4	15,5	36,5

ISO Standard 5599/1 fixes the dimensions of the bearing surface of the valve and provides accommodation between two contiguous planes while guaranteeing at the time of replacement, that any suitable valve can be inserted in the manifold assembly. It also provides a clear numbering system for the ports, Main connecting ports:

- 1 = Supply port
- 2 - 4 = Exhaust
- 2 - 4 = Use
- 3 - 5 = Exhaust
- 12 - 14 = Pilots

(e.g. single electrical impulse solenoid mounted side 14 single pneumatic impulse control at 14)

Standard manual overrides

Functioning	Suitable for valve	Symbol/Part no.
1 = with 2 position screw	BE	⊖
2 = with button with tool	BE	→
3 = with recessed button, 1 position	BE12	→

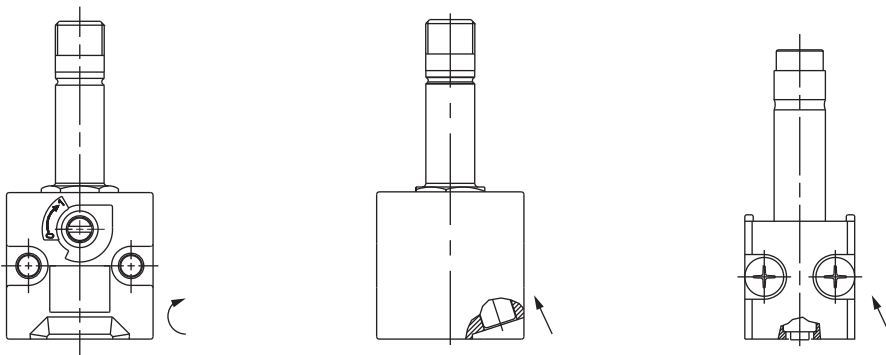

BE/BE12 Series

ISO 5599/1 Valves

BE ISO 5599/1 Valves

Double electric impulse

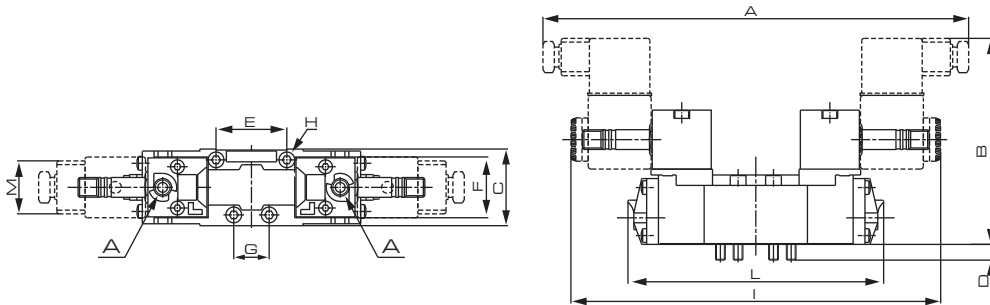

	ISO 1	ISO 2	ISO 3	ISO 4
A	211	226	247	268
B	105	105	118	118
C	39	52	64	74
D	5	5	10	10
E	36	48	64	80
F	28	38	48	58
G	18	24	32	40
H	M5x38	M6x35	M8x50	M8x50
I	191	207	226	248
L	128	145	191	222
M	30	30	30	30

A Manual override

Symbol	Control	Return	Size	Pressure bar	Response Time (ms)		Weight Kg	Part no.	
					En.	De-en.			
MIXED SYSTEM									
5/2		electric amplified	electric amplified	1	1÷10	16	16	0,39	BE-3020
				2	1÷10	17	17	0,64	BE-4020
				3	1÷10	23	23	1,04	BE-5020
				4	1,3÷10	25	25	1,21	BE-6020
5/2		electric amplified	electric not amplified	1	2÷10	16	34	0,39	BE-3030
				2	2÷10	17	29	0,64	BE-4030
				3	2,2÷10	23	54	1,04	BE-5030
				4	2,2÷10	25	45	1,21	BE-6030
5/3 o.c.		electric amplified	electric amplified	1	3÷10	50	26	0,39	BE-3200*
				2	3÷10	54	24	0,64	BE-4200*
				3	3÷10	108	36	1,04	BE-5200*
				4	3÷10	115	115	1,21	BE-6200*
5/3 p.c.		electric amplified	electric amplified	1	2÷10	50	26	0,39	BE-3205
				2	2,3÷10	54	24	0,64	BE-4205
				3	2,5÷10	108	36	1,04	BE-5205
				4	3÷10	115	115	1,21	BE-6205
SPOOL SYSTEM									
5/2		electric amplified	electric amplified	1	1÷10	17	17	0,39	BE-3720
				2	1÷10	18	18	0,64	BE-4720
				3	1÷10	26	26	1,04	BE-5720
				4	1÷10	27	27	1,21	BE-6720
5/2		electric amplified	electric not amplified	1	1,8÷10	17	28	0,39	BE-3730
				2	1,8÷10	18	25	0,64	BE-4730
				3	2,5÷10	26	46	1,04	BE-5730
				4	2,5÷10	27	42	1,21	BE-6730
5/3 o.c.		electric amplified	electric amplified	1	2,3÷10	17	25	0,39	BE-3900
				2	2,5÷10	18	27	0,64	BE-4900
				3	2,5÷10	26	50	1,04	BE-5900
				4	2,5÷10	30	47	1,21	BE-6900
5/3 c.c.		electric amplified	electric amplified	1	2,3÷10	17	25	0,39	BE-3940
				2	2,5÷10	18	27	0,64	BE-4940
				3	2,5÷10	26	50	1,04	BE-5940
				4	2,5÷10	30	47	1,21	BE-6940

o.c. = open centres c.c. = closed centres p.c. = pressurized centres
 For manual version with button, add "U" to the end of the part number

* = For version with manual override contact our Sales Department

BE/BE12 Series

ISO 5599/1 Valves

BE ISO 5599/1 Valves

Single/double pneumatic impulse

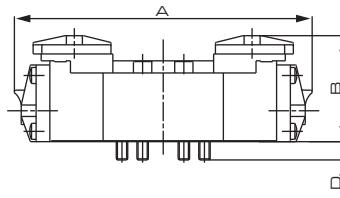
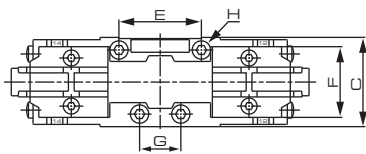

	ISO 1	ISO 2	ISO 3	ISO 4
A	128	145	191	222
B	47	47	63	63
C	39	52	64	74
D	5	5	10	10
E	36	48	64	80
F	28	38	48	58
G	18	24	32	40
H	M5x38	M6x35	M8x50	M8x50

Symbol	Control 14	Return 12	Size	Pressure bar	Response En.	Time (ms) De-en.	Weight Kg	Part no.
MIXED SYSTEM								
5/2		pneumomechanical spring	1	2÷10	9	18	0,30	BE-3100
			2	2,3÷10	11	14	0,40	BE-4100
			3	2,5÷10	19	49	0,65	BE-5100
			4	3÷10	23	46	0,87	BE-6100
5/2		pneumatic amplified	1	1÷10	5	5	0,30	BE-3150
			2	1÷10	6	6	0,40	BE-4150
			3	1÷10	10	10	0,65	BE-5150
			4	1,3÷10	12	12	0,87	BE-6150
5/2		pneumatic not amplified	1	2÷10	5	16	0,30	BE-3170
			2	2÷10	6	13	0,40	BE-4170
			3	2,2÷10	10	35	0,65	BE-5170
			4	2,2÷10	12	32	0,87	BE-6170
SPOOL SYSTEM								
5/2		pneumomechanical spring	1	1,8÷10	11	22	0,30	BE-3800
			2	2÷10	13	19	0,40	BE-4800
			3	2,2÷10	21	52	0,65	BE-5800
			4	2,8÷10	24	29	0,87	BE-6800
5/2		pneumatic amplified	1	0,8÷10	6	6	0,30	BE-3850
			2	1÷10	7	7	0,40	BE-4850
			3	1÷10	12	12	0,65	BE-5850
			4	1÷10	14	14	0,87	BE-6850
5/2		pneumatic not amplified	1	1,5÷10	6	15	0,30	BE-3870
			2	1,8÷10	7	14	0,40	BE-4870
			3	2÷10	12	38	0,65	BE-5870
			4	2÷10	14	31	0,87	BE-6870

Single electric impulse

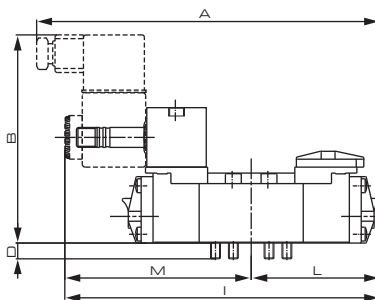
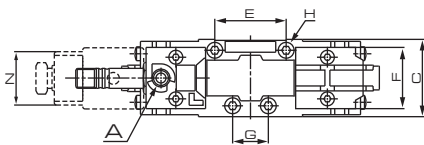

	ISO 1	ISO 2	ISO 3	ISO 4
A	169,5	195,5	219	253
B	105	105	118	118
C	39	52	64	74
D	5	5	10	10
E	36	48	64	80
F	28	38	48	58
G	18	24	32	40
H	M5x38	M6x35	M8x50	M8x50
I	159,5	176	208,5	235
L	64	72,5	95,5	111
M	95,5	103,5	113	124
N	30	30	30	30

A: Manual override

Symbol	Control 14	Return 12	Size	Pressure bar	Response En.	Time (ms) De-en.	Weight Kg	Part no.
MIXED SYSTEM								
5/2		pneumomechanical spring	1	2÷10	20	32	0,37	BE-3000
			2	2,3÷10	24	25	0,47	BE-4000
			3	2,5÷10	32	71	0,82	BE-5000
			4	3÷10	38	62	1,04	BE-6000
5/2		pneumatic amplified	1	1÷10	16	6	0,37	BE-3060
			2	1÷10	17	7	0,47	BE-4060
			3	1÷10	23	15	0,82	BE-5060
			4	1,3÷10	25	16	1,04	BE-6060
SPOOL SYSTEM								
5/2		pneumomechanical spring	1	2÷10	21	35	0,37	BE-3700
			2	2,2÷10	24	30	0,47	BE-4700
			3	2,3÷10	33	74	0,82	BE-5700
			4	2,8÷10	39	68	1,04	BE-6700
5/2		pneumatic amplified	1	1÷10	17	8	0,37	BE-3760
			2	1÷10	18	9	0,47	BE-4760
			3	1÷10	26	17	0,82	BE-5760
			4	1,3÷10	27	18	1,04	BE-6760

For manual version with button, add "U" to the end of the part number
Electrovalves are supplied without coil, connector and locking ring

BE/BE12 Series

ISO 5599/1 Valves

BE12 ISO 5599/1 Valves with M12 male cov

Single/Double electric impulse

The use of pneumatic component in the automotive field, coupled with electric components, led to the development of a traditional ISO valve with electric connector M12 placed in central position for both valves with single as well as double electric control.

	Symbol	Control	Return	Size	Pressure bar	Response Time (ms)		Weight Kg	Part no.
						En.	De-en.		
		14	12						
	SINGLE IMPULSE - MIXED SYSTEM								
5/2		electric amplified	pneumomechanical spring	1	2÷9	18	29	0,45	BE12-3000
				2	2,3÷9	23	24	0,55	BE12-4000
				3	2,5÷9	35	78	0,90	BE12-5000
	SINGLE IMPULSE - SPOOL SYSTEM								
5/2		electric amplified	pneumomechanical spring	1	2÷9	19	32	0,45	BE12-3700
				2	2,2÷9	23	28	0,55	BE12-4700
				3	2,3÷9	36	82	0,90	BE12-5700
	DOUBLE IMPULSE - MIXED SYSTEM								
5/2		electric amplified	electric amplified	1	1÷9	14	14	0,55	BE12-3020
				2	1÷9	16	16	0,80	BE12-4020
				3	1÷9	25	25	1,20	BE12-5020
5/3 p.c.		electric amplified	electric amplified	1	2÷9	45	23	0,55	BE12-3205
				2	2,3÷9	51	23	0,80	BE12-4205
				3	2,5÷9	119	40	1,20	BE12-5205
	DOUBLE IMPULSE - SPOOL SYSTEM								
5/2		electric amplified	electric amplified	1	1÷9	15	15	0,55	BE12-3720
				2	1÷9	17	17	0,80	BE12-4720
				3	1÷9	29	29	1,20	BE12-5720
5/3 o.c.		electric amplified	electric amplified	1	2,3÷9	15	22	0,55	BE12-3900
				2	2,5÷9	17	26	0,80	BE12-4900
				3	2,5÷9	29	55	1,20	BE12-5900
5/3 c.c.		electric amplified	electric amplified	1	2,3÷9	15	22	0,55	BE12-3940
				2	2,5÷9	17	26	0,80	BE12-4940
				3	2,5÷9	29	55	1,20	BE12-5940

o.c. = open centres c.c. = closed centres p.c. = pressurized centres

Valves are supplied with 24 V DC coil

Single electric impulse

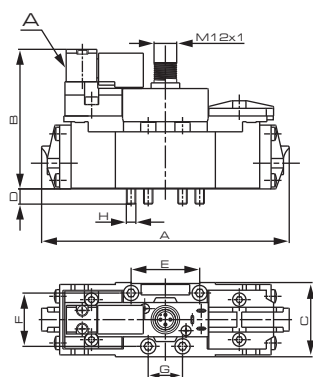

Double electric impulse

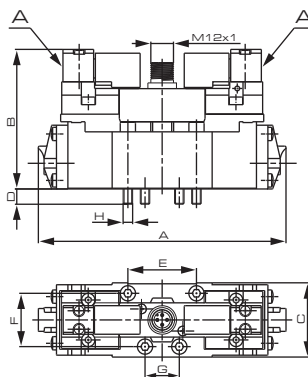

ELECTRIC CHARACTERISTICS

Central electric connector M12x1

IP 65 protection degree

24 V DC voltage

2,5 W nominal power

DD-052** series coil (without faston)

ED 100%

LED indicator

Available upon request other voltages
max 48 V DC

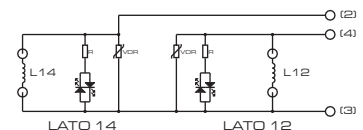

	ISO 1	ISO 2	ISO 3
A	128	145	191
B	73	73	90
C	39	52	64
D	5	5	10
E	36	48	64
F	28	38	48
G	18	24	32
H	M5x38	M6x35	M8x50

A Manual override

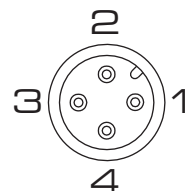

BE/BE12 Series

ISO 5599/1 Valves

BF Side connections sub-bases

ISO 1 Single sub-base, side connections

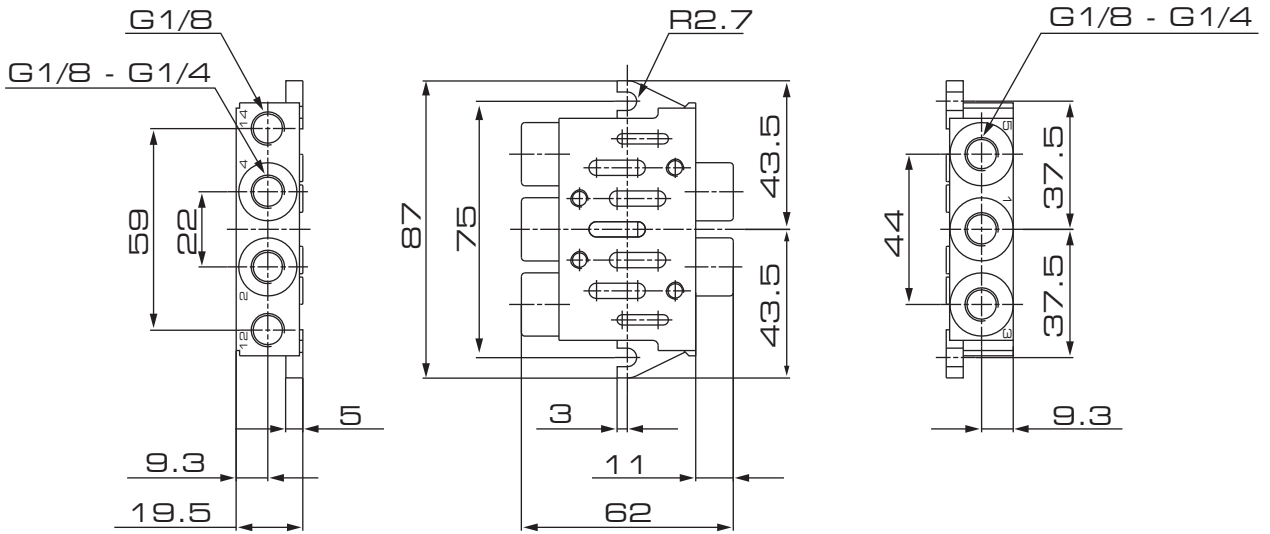

Notes	Connection	Material	Weight Kg	Part no.
in line connections	G1/8	zamak	0,25	BF-1060
in line connections	G1/4	zamak	0,25	BF-1061

1 = Supply port
2 - 4 = Use

3 - 5 = Exhaust
12 - 14 = Pilots

ISO 2 Single sub-base, side connections

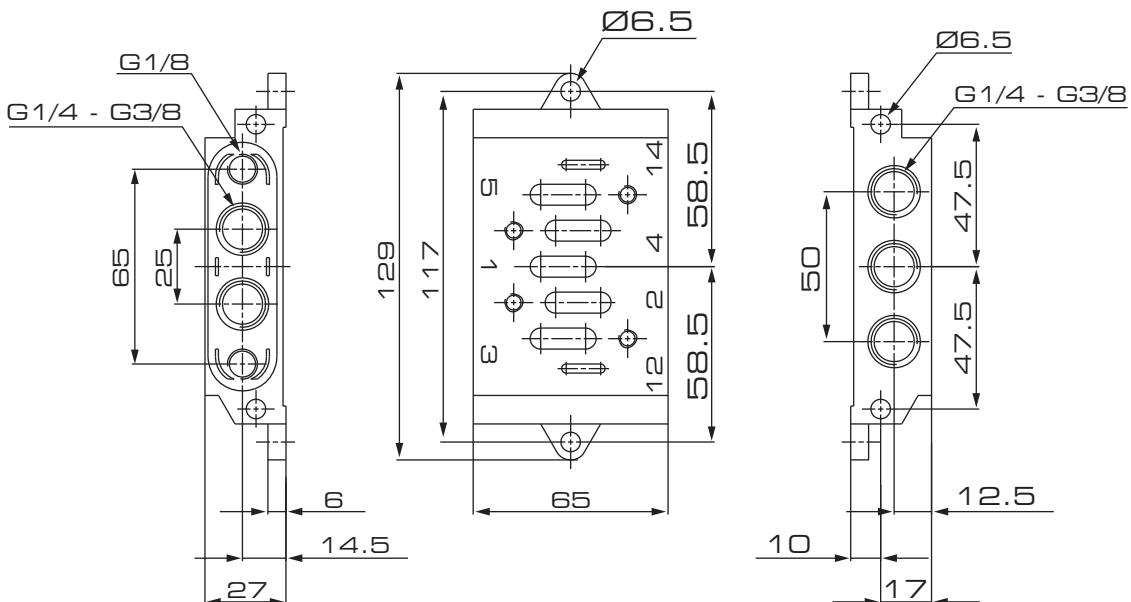

Notes	Connection	Material	Weight Kg	Part no.
in line connections	G1/4	zamak	0,65	BF-1150
in line connections	G3/8	zamak	0,65	BF-1151

1 = Supply port
2 - 4 = Use

3 - 5 = Exhaust
12 - 14 = Pilots

BE/BE12 Series

ISO 5599/1 Valves

BF Side connections sub-bases

ISO 3 Single sub-base, side connections

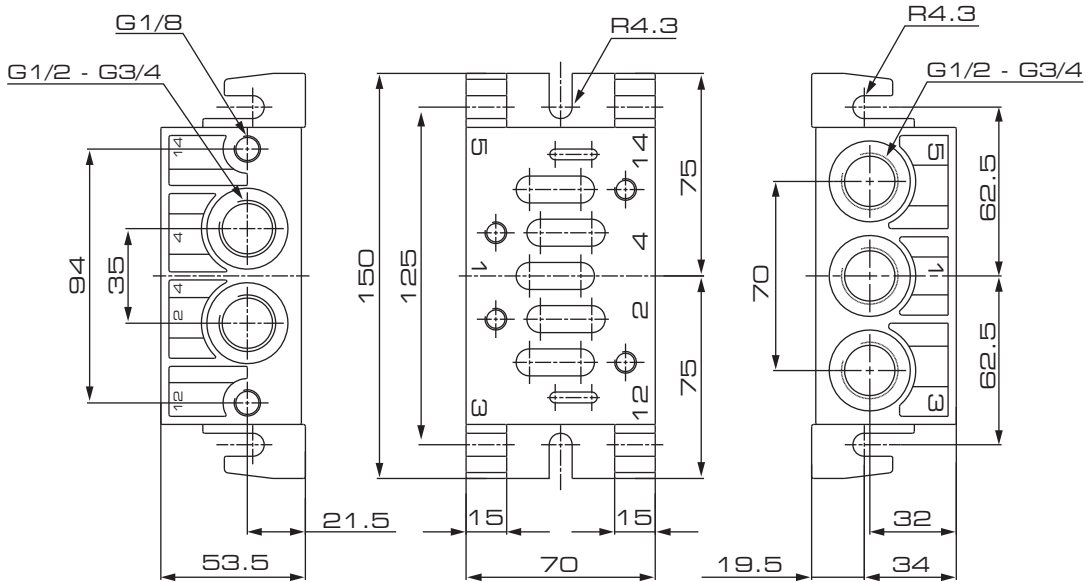

Notes	Connection	Material	Weight Kg	Part no.
in line connections	G1/2	aluminium	0,74	BF-3060
in line connections	G3/4	aluminium	0,74	BF-3061

1 = Supply port
2 - 4 = Use

3 - 5 = Exhaust
12 - 14 = Pilots

ISO 4 Single sub-base, side connections

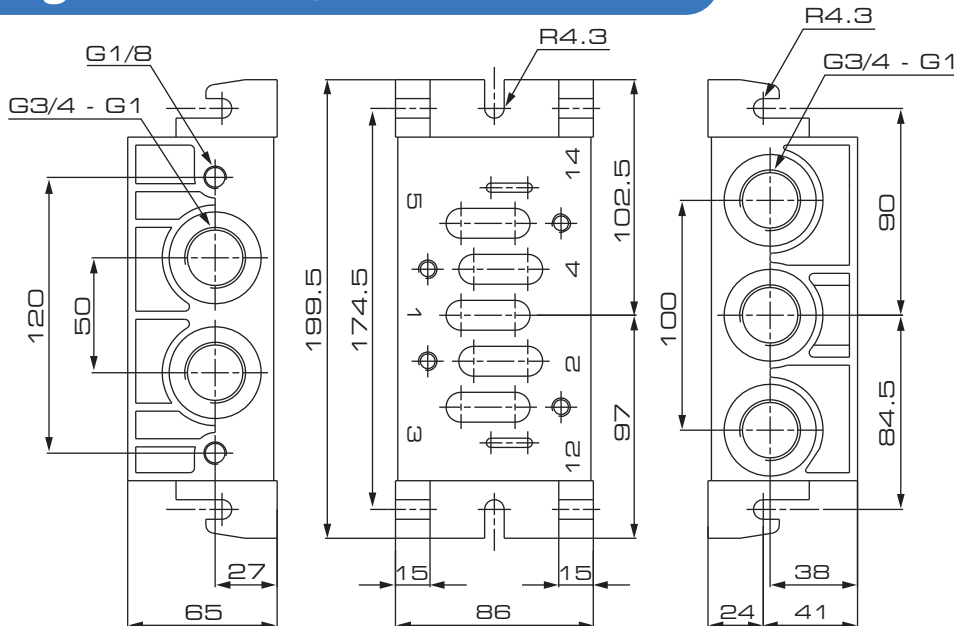

Notes	Connection	Material	Weight Kg	Part no.
in line connections	G3/4	aluminium	1,28	BF-4060
dorsal and side connections	G1	aluminium	1,28	BF-4061

1 = Supply port
2 - 4 = Use

3 - 5 = Exhaust
12 - 14 = Pilots

BE/BE12 Series

ISO 5599/1 Valves

BE12 Dorsal connections sub-bases

ISO 1 Single modular or Manifold sub-base, dorsal connections, separate exhausts

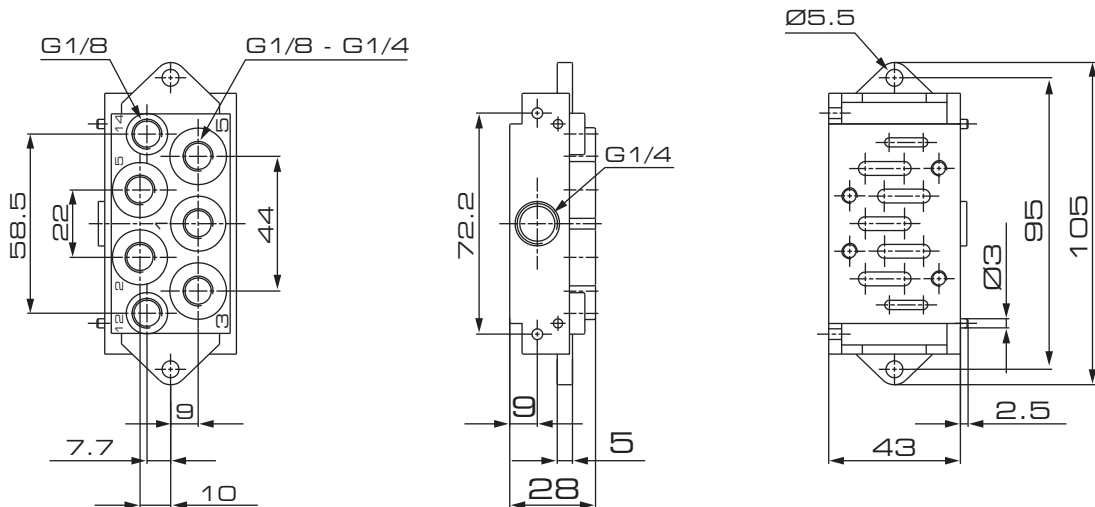

Notes	Connection	Material	Weight Kg	Part no.
dorsal connections	G1/8	zamak	0,35	BF-1062
dorsal connections	G1/4	zamak	0,33	BF-1063

Single assembly: close side ports (G1/8 - G1/4)
 Manifold assembly with common inlet: close dorsal connections n.1
 With incorporated screws and seal

1 = Supply port 3 - 5 = Exhaust
 2 - 4 = Use 12 - 14 = Pilots

ISO 2 Single sub-base, dorsal connections

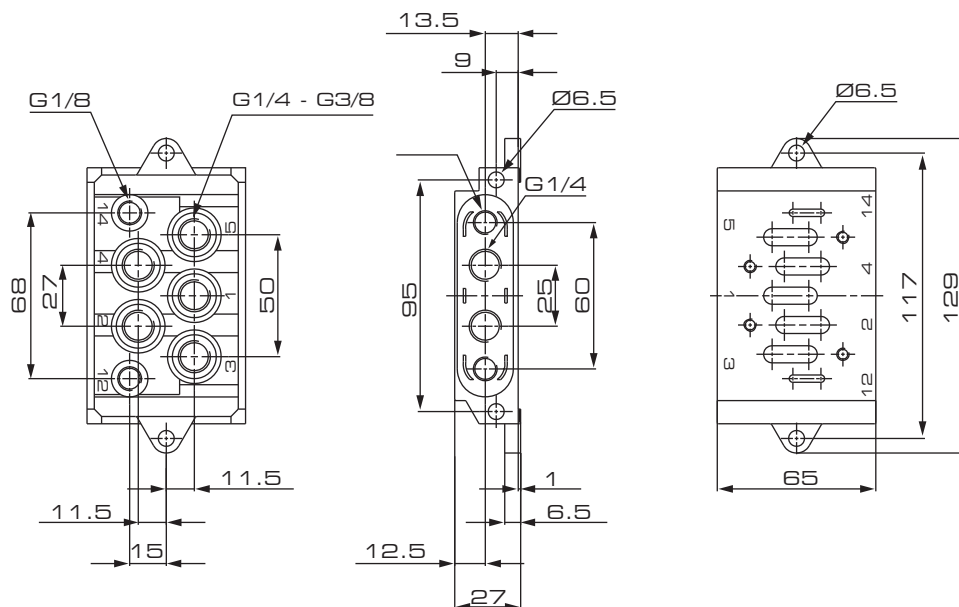

Notes	Connection	Material	Weight Kg	Part no.
dorsal connections	G1/4	zamak	0,65	BF-1152
dorsal connections	G3/8	zamak	0,65	BF-1153

1 = Supply port 3 - 5 = Exhaust
 2 - 4 = Use 12 - 14 = Pilots

BE/BE12 Series

ISO 5599/1 Valves

BE12 Dorsal connections sub-bases

ISO 3 Single sub-base, dorsal connections

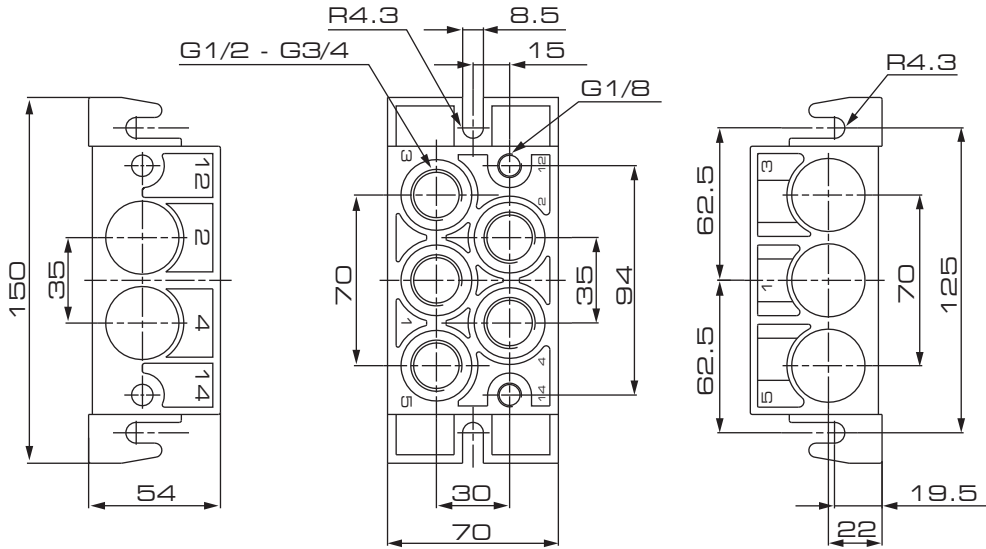

Notes	Connection	Material	Weight	Part no.
dorsal connection	G3/4	aluminium	0,72	BF-3063

1 = Supply port 3 - 5 = Exhaust
 2 - 4 = Use 12 - 14 = Pilots

ISO 4 Single sub-base, dorsal connections

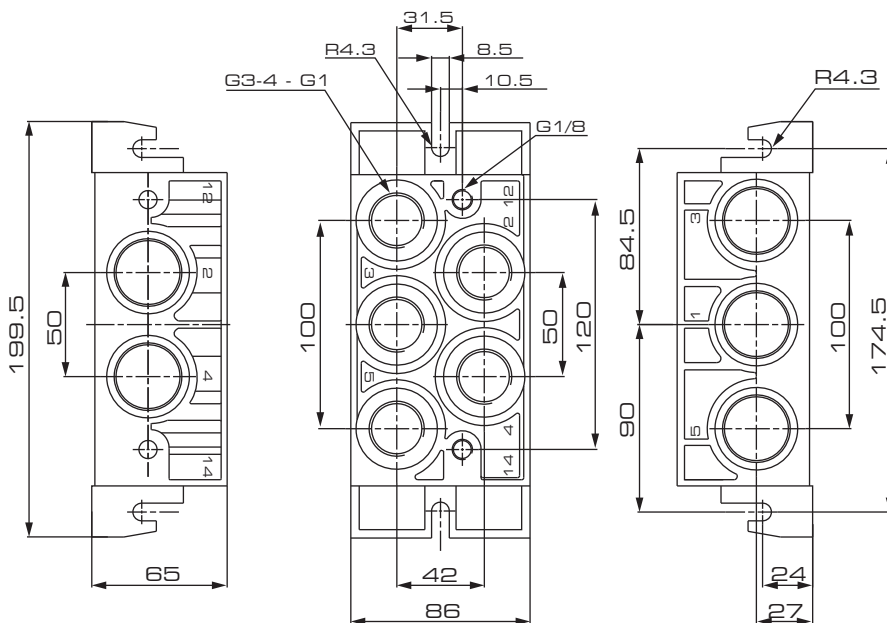

Notes	Connection	Material	Weight	Part no.
dorsal connections	G3/4	aluminium	1,24	BF-4062
dorsal connections	G1	aluminium	1,24	BF-4063

1 = Supply port 3 - 5 = Exhaust
 2 - 4 = Use 12 - 14 = Pilots

BE/BE12 Series

ISO 5599/1 Valves

BF Manifold sub-bases

ISO 1 Manifold universal system sub-base, dorsal and side connections, conveyed exhausts

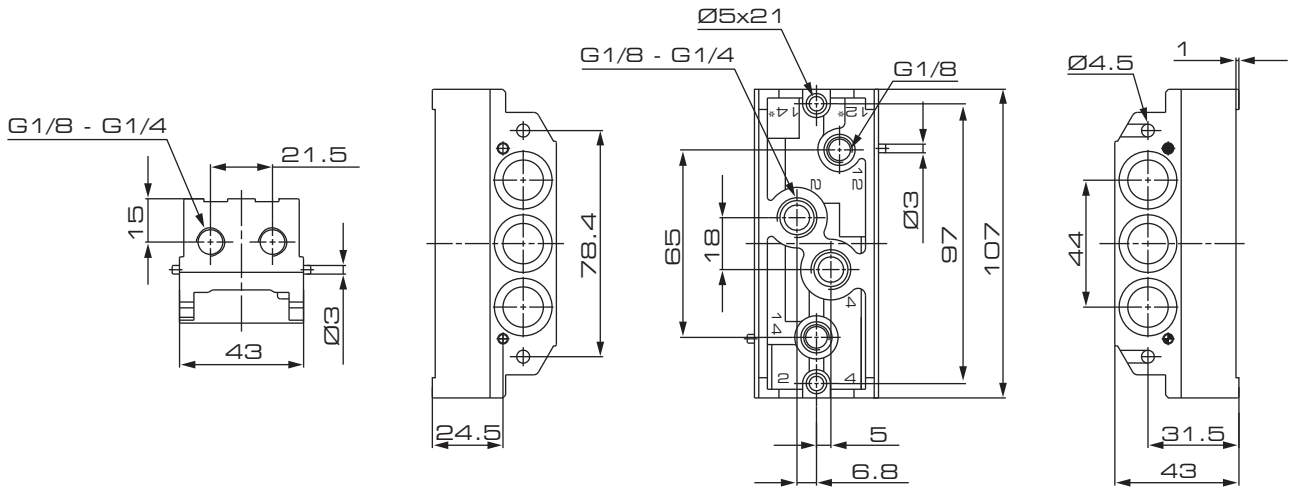

Notes	Connection	Material	Weight Kg	Part no.
dorsal and side connections	G1/8	aluminium	0,28	BF-1071
dorsal and side connections	G1/4	aluminium	0,28	BF-1072
side pneumatic impulses	G1/8	aluminium	0,30	BF-1071S
side pneumatic impulses	G1/4	aluminium	0,30	BF-1072S

Dorsal and side connections possible. Close unused ports with caps.
With incorporated screws, seals and caps included

- 1 = Supply port
2 - 4 = Use
3 - 5 = Exhaust
12 - 14 = Pilots
12" - 14" = Side Pilots

ISO 1 Manifold universal system inlet plate

- A On top connections
B In line connections
C Dorsal connections

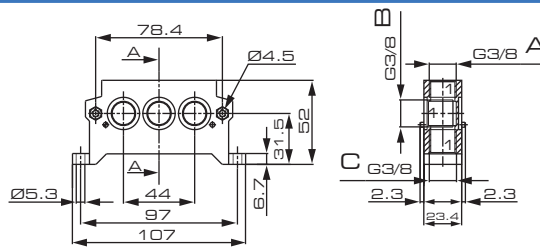

Notes	Connection	Material	Weight Kg	Part no.
on top connections	G3/8	zamak	0,35	BF-1065
dorsal connections	G3/8	zamak	0,35	BF-1066

- 1 = Supply port
3 - 5 = Exhaust

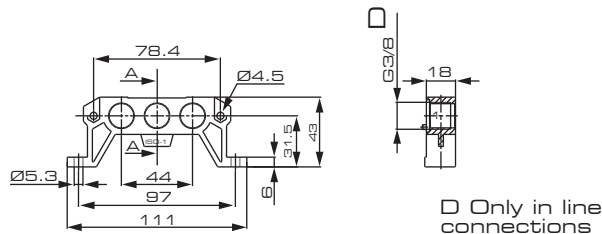

Notes	Connection	Material	Weight Kg	Part no.
only in line connections	G3/8	aluminium	0,12	BF-1068

- 1 = Supply port
3 - 5 = Exhaust

When battery exceeds 4 units, the mounting of 2 plates is recommended
Mixed version available upon request. With incorporated screws and seal

BE/BE12 Series

ISO 5599/1 Valves

BF Manifold sub-bases

ISO 1 Manifold universal diaphragm

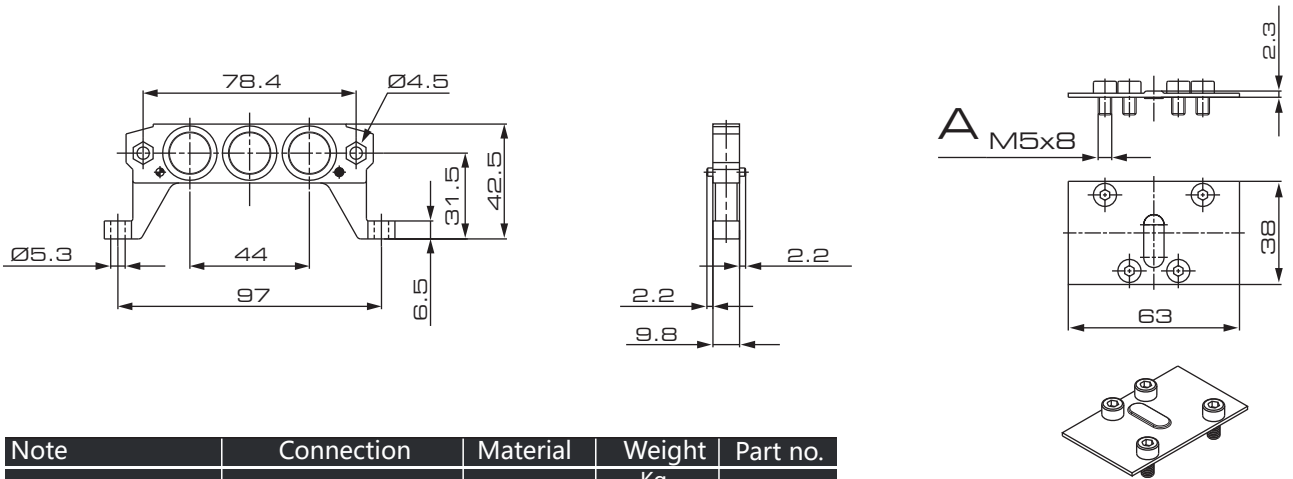

Note	Connection	Material	Weight Kg	Part no.
-	-	zamak	0,09	BF-1070

A ISO 4762

ISO 1 - Closing plate for sub-base 1
material: steel
weight: 0,03 Kg (for all sub-base versions)

The diaphragm is not only the end plate of the manifold but it is also coupled with the exhaust regulator to separate two sub-bases and regulate the valves independently. In this case break the central blind hole.

To get two or more pressures, break the two side blind holes.

ISO 2 Manifold universal system sub-base, dorsal and side connections, conveyed exhausts

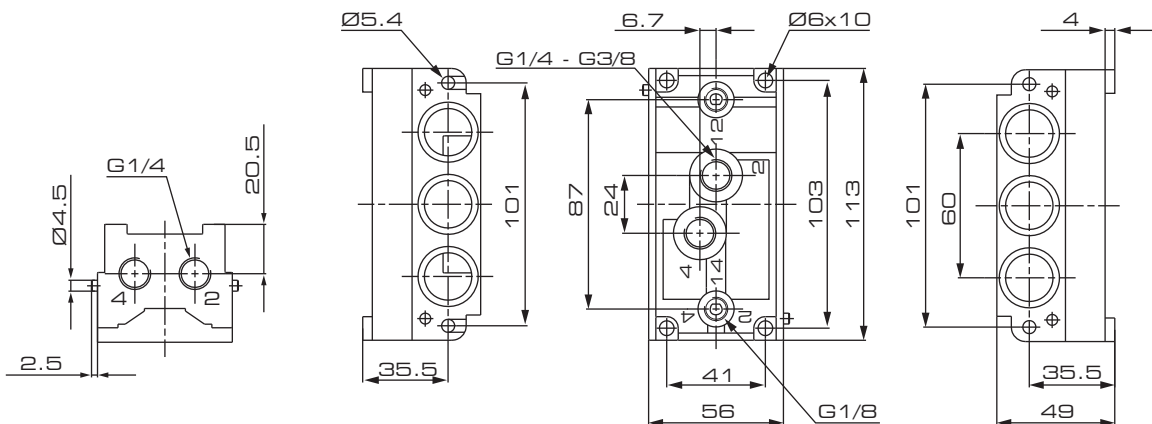

Notes	Connection	Material	Weight Kg	Part no.
dorsal and side connections	G1/4	zamak	0,80	BF-1160
dorsal and side connections	G3/8	zamak	0,80	BF-1161

Dorsal and side connections possible. Close unused ports with caps.
With incorporated screw, seals and caps included

1 = Supply port
2 - 4 = Use

3 - 5 = Exhaust
12 - 14 = Pilots

BE/BE12 Series

ISO 5599/1 Valves

BF Manifold sub-bases / BF-1175

ISO 2 Manifold universal system inlet plate

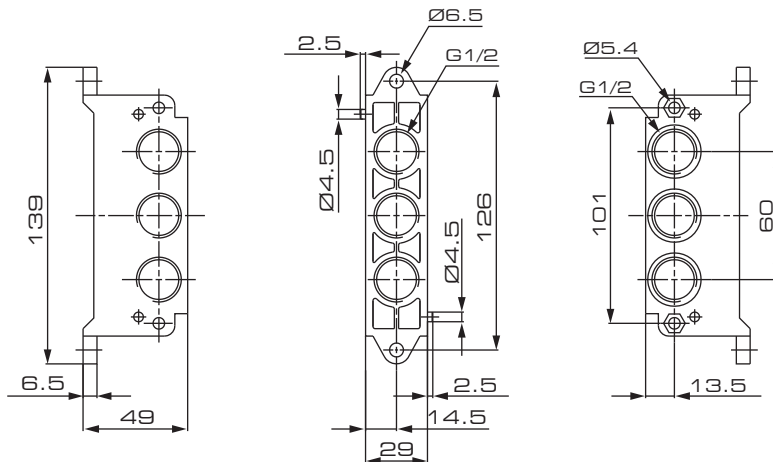

Notes	Connection	Material	Weight Kg	Part no.
in line connections	G1/2	zamak	0,46	BF-1154
dorsal connections	G1/2	zamak	0,46	BF-1155

1 = Supply port 3 - 5 = Exhaust
2 - 4 = Use 12 - 14 = Pilots

Mixed version available upon request
With incorporated screw and seals

ISO 2 Manifold universal system diaphragm

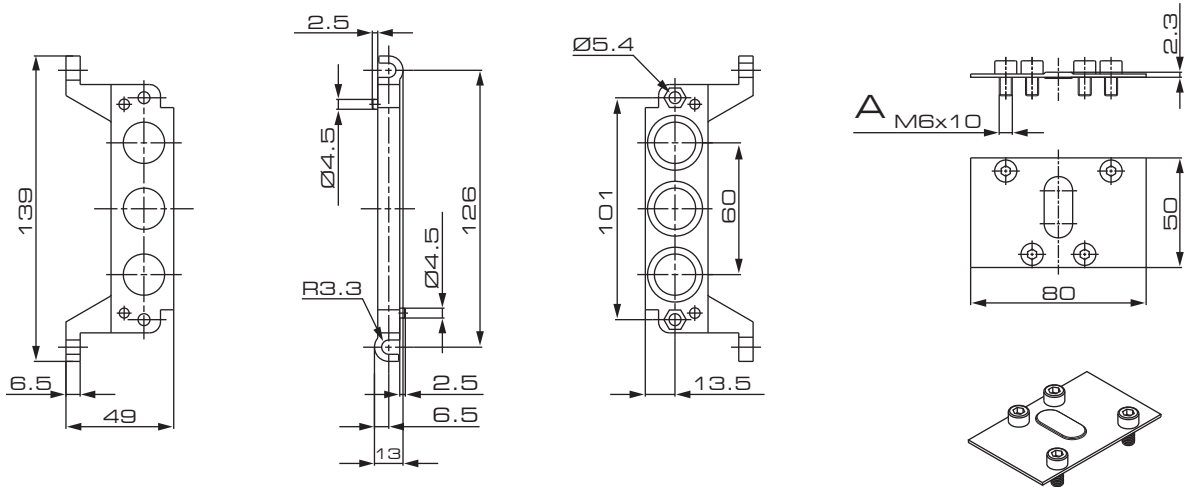

Notes	Connection	Material	Weight Kg	Part no.
-	-	zamak	0,16	BF-1162

The diaphragm is not only the end plate of the manifold but it is also coupled with the exhaust regulator to separate two sub-bases and regulate the valves independently. In this case break the central blind hole.
To get two or more pressures, break the two side blind holes.

A ISO 4762

ISO 2 - Closing plate for sub-base 2
material: steel
weight: 0,05 Kg (for all sub-base versions)

BE/BE12 Series

ISO 5599/1 Valves

BF Manifold sub-bases / BF-3175 / BF-3082

ISO 3 Manifold universal system sub-base, dorsal and side connections, conveyed exhausts

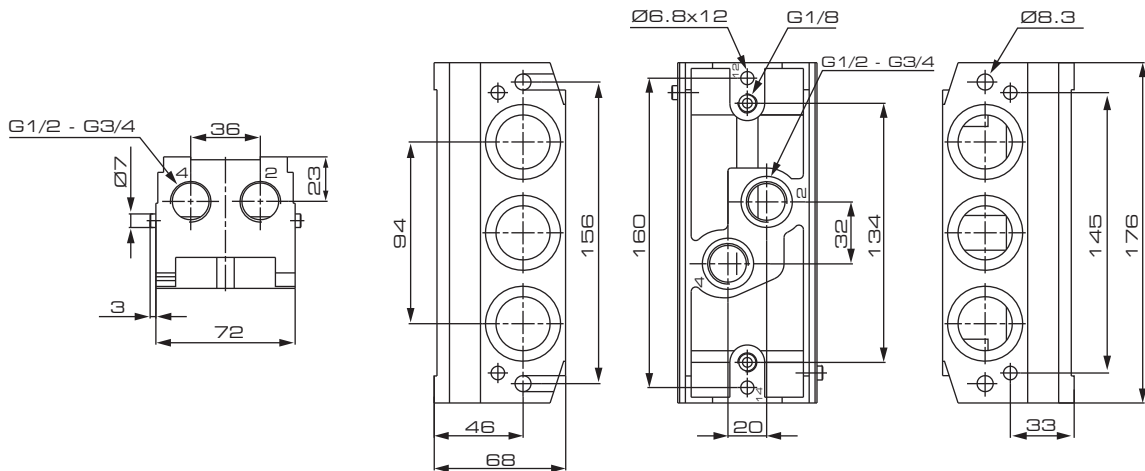

Notes	Connection	Material	Weight Kg	Part no.
dorsal and side connections	G1/2	aluminium	1,10	BF-3071
dorsal and side connections	G3/4	aluminium	1,10	BF-3072

1 = Supply port 3 - 5 = Exhaust
2 - 4 = Use 12 - 14 = Pilots

Dorsal and side connections possible. Close unused ports with caps.
With incorporated screws, seals and caps included

ISO 3 Manifold universal system inlet plate

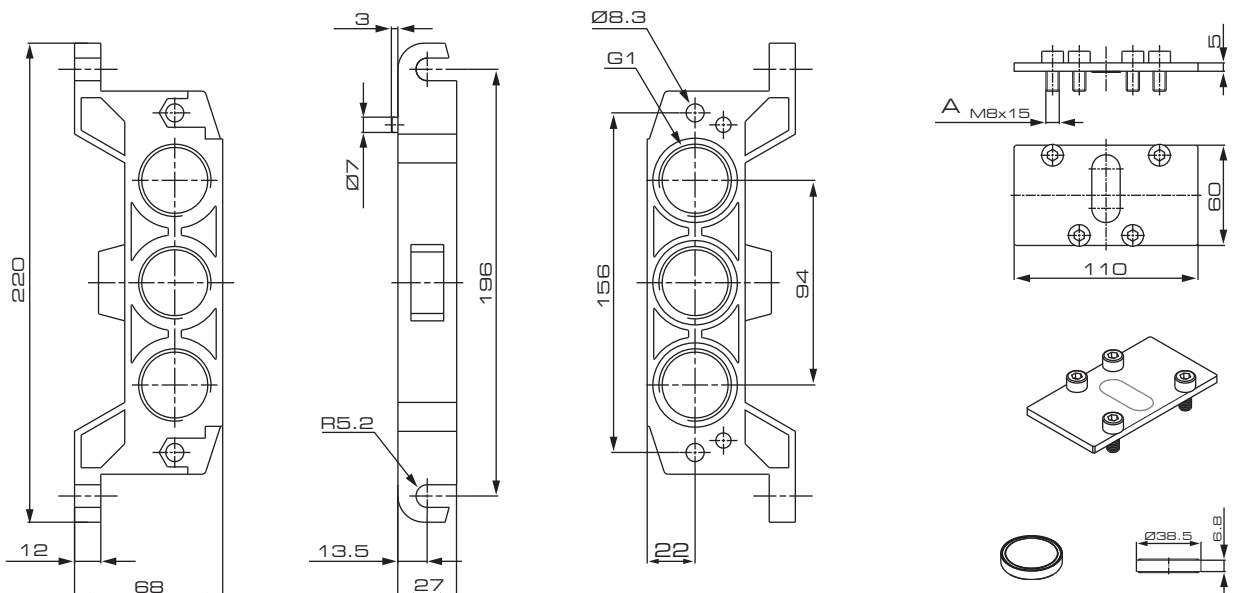

Notes	Connection	Material	Weight Kg	Part no.
in line connections	G1	aluminium	0,44	BF-3064

When battery exceeds 4 units, the mounting of 2 plates is recommended
Mixed version available upon request
With incorporated screws and seals

A ISO 4762

ISO 3 - Closing plate for sub-base 3
material: steel
weight: 0,08 Kg (for all sub-base versions)

ISO 3 - Universal system Cap
material: steel
weight: 0,20 Kg
To be used to reach two pressures

BE/BE12 Series

ISO 5599/1 Valves

BF Accessories / BF-1190 / BF-3190 / BF-3191

Accessories BF-1190

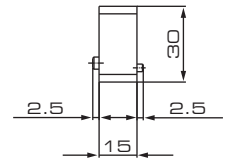
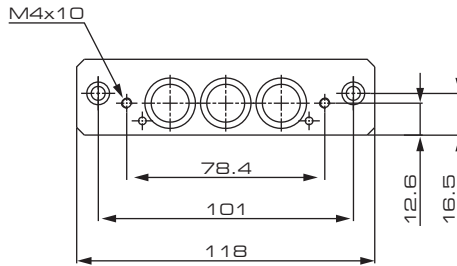
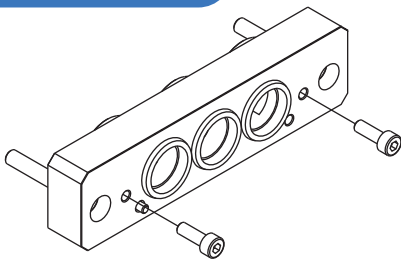

Connecting interface for universal sub-bases size 1 and 2
material: steel
weight: 0,11 Kg
It allows the use of size 1 and 2 valves in one manifold with conveyed pressure and exhausts.
(Upon request: pressure and/or exhausts separated)

Accessories BF-3190

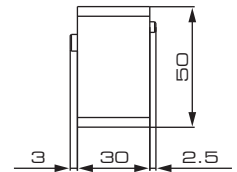
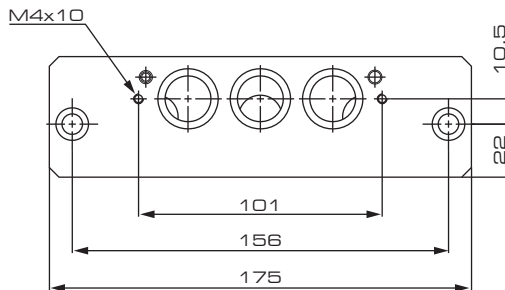
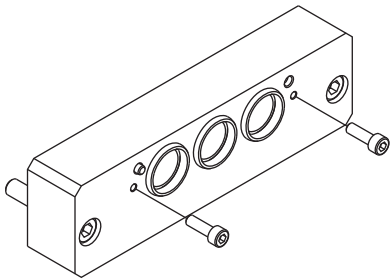

Connecting interface for universal sub-bases size 2 and 3
material: steel
weight: 0,57 Kg
It allows the use of size 2 and 3 valves in one manifold with conveyed pressure and exhausts
(Upon request: pressure and/or exhausts separated).

Accessories BF-3191

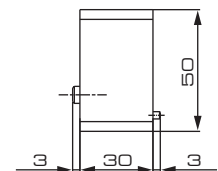
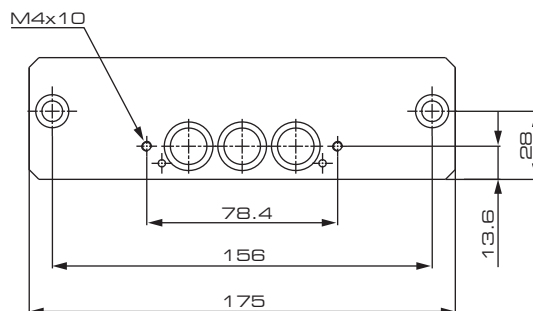
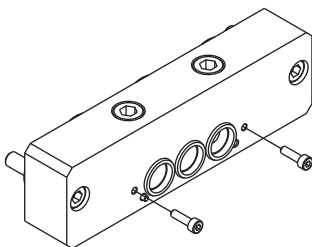

Connecting interface for universal sub-bases size 1 and 3
material: steel
weight: 0,57 Kg
It allows the use of size 1 and 3 valves in one manifold with conveyed pressure and exhausts.
(Upon request: pressure and/or exhausts separated).